

DPG 100 Test Gauge – Operating Instructions

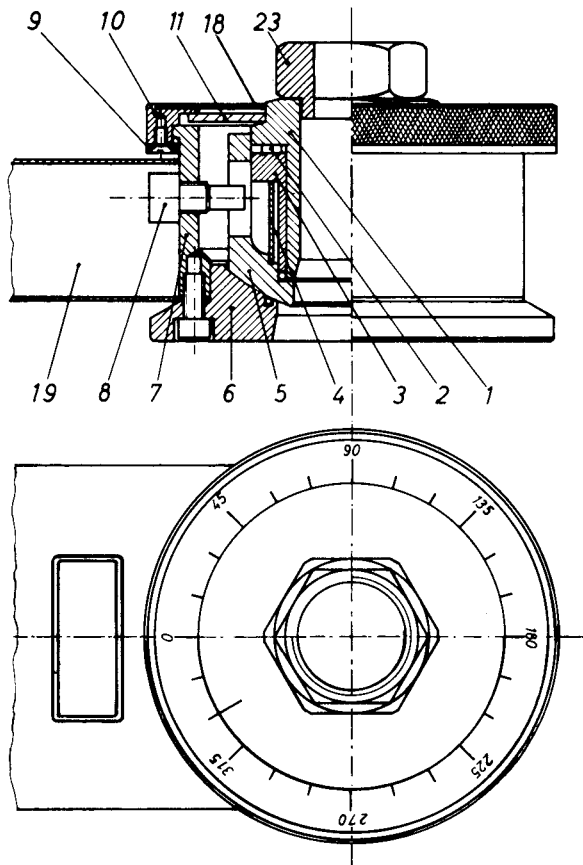

Technical Data

Weight:	3 kg
Thread size:	M6 to M24
Loading range:	max. 100 kN
Max. variance of readings at room temperature:	max. 1.0 kN typical ± 0.3 kN
Power supply:	9-volt transistor battery, e.g. Mallory Alkaline MN 1604
Temperature range for storage:	-20°C to $+80^{\circ}\text{C}$
use:	-5°C to $+60^{\circ}\text{C}$

Technical Description

Mechanical working principle

The applied load acts on measuring ring (4) via the screwed-on thread adaptor (23), sleeve (1), needle bearing (2) and pressure sleeve (3). On tightening the adaptor, any tilt of the anchor is compensated for by the spherical section of the housing (6) and the support ring (5). The anchor is always loaded in the direction of its longitudinal axis. The hexagon on sleeve (1) moves the indicator (11). The rotatable scale ring (10) then shows the rotary movement that has been carried out in degrees on scale (18). This measurement of the movement is relatively inaccurate for two reasons:

- there are changes in the surface of the base material beneath the bearing surface of the test gauge and
- there is some deformation of the metal of the thread adaptors.

These two influencing factors increase the reading. If more accurate measurement of the movement is necessary, it is recommended that a dial gauge is put on the thread adaptor (23).

Schematic diagram of measuring circuit

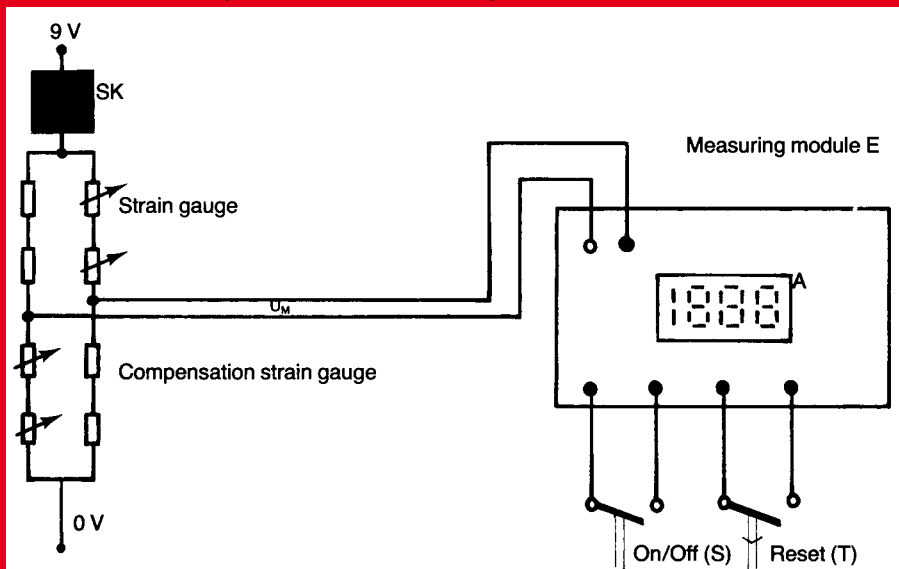

Electronic working principle

The 4 strain gauges that are bonded to the measuring ring are linked with the 4 compensation strain gauges that are adhered to a square section, to form a Wheatstone bridge. The diagonal voltage, that is described as the measuring voltage, U_M , is amplified by the measuring module, E, and shown in kN by the LCD indicator, (A). The on-off switch, (S), switches the electronic circuit on and the gauge is then ready for use. The reset button, (T), is used to set the gauge at zero after it has been connected to an anchor and the adaptor has been tightened slightly. As a result of the noise of the circuit and the digitalization, the zero reading can also be shown as 0.1 kN. The voltage stabilizer, (SK), reduces the variable battery voltage to a stabilized bridge voltage of 2.6 V. As a result the life of the battery is considerably extended and the accuracy of the reading considerably improved.



Screw the threaded rod in internally threaded anchors such as the HKD (HDI) or TDD (HSS). In the case of the HSL replace the bolt by the threaded rod.



The gauge can be connected straight to the HSA (HKB), HVA (adhesive) and HSLG heavy-duty stud anchor. The central bore is placed over the protruding threaded section of the anchor.

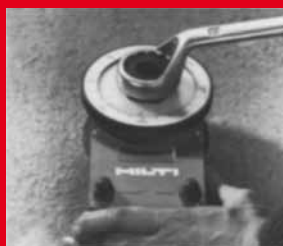

The thread adaptor is screwed on and connects the anchor to the gauge.

Testing operations

- Switch on the gauge at the on/off switch. The digits in the display will change rapidly and then remain constant.
- Connect the gauge to the anchor (see photos).
- Press the reset button to obtain the zero reading on the digital display. A figure of 0.0 to 0.1 kN will be indicated.
- Tighten the thread adaptor lightly, by hand (to approx. 0.3 to 0.5 kN).
- Turn the scale ring to bring the indicator mark in line with the zero on the scale if the movement of the anchor fastening has to be measured.



6. Tighten the thread adaptor until the specified inspection load is reached, using the ring wrench.



An inspection load cannot be specified generally. For normal applications we recommend that the inspection loads given

in the table below are used i.e. inspection load = 1.5 × recommended load.

7. The rotary movement of the scale ring gives an idea of the movement (deformation) of the anchor fastening. However, deformation of the threaded rod (threaded section of the anchor) and the base material must be taken into account if the measurement needs to be more accurate. The movement can also be measured using a dial gauge. If the anchor begins to work loose under the inspection load, this will be felt clearly through the ring wrench.

Maintenance of the test gauge

We would like to draw your attention once again to the following points to ensure that your DPG 100 gauge remains in good working order for precision measurement for as long as possible.

a) The temperature range in which the gauge may be used and stored, as shown in the technical data, must be kept to.

The display must be kept out of direct sunlight.

b) The gauge may not be overloaded.

c) The gauge should only be carried around in the supplied case, as far as this is possible.

d) Anchors may **not** be tested until failure of this gauge.

e) If for any reason the gauge ceases to function, it may only

be repaired at Hilti AG, Schaan.

Changing the battery



The gauge is assembled and calibrated as well as checked for accuracy at the manufacturing plant.

The DPG 100 gauge is a precision measuring instrument and must be treated as such.

The only «maintenance» required of the user is that he changes the battery when it runs down.

It is time to replace the battery if the figure on the display changes very rapidly when the reset button (T) is pressed and the gauge is switched on. It is still possible to continue testing with the gauge until the battery is replaced, using the indicated zero figure. To change the battery the cover at the front of the gauge bearing the

nameplate has to be removed. Care must be taken to ensure the battery is connected correctly (right hole).

DPG 100 Testing Loads in kN (test load $\hat{=}$ 1.5 × recommended load)

	Concr. strength M6	M8	M10	M12	M16	M20	M24
Anchor	25 N/mm ²	–	9.6	14.1	20.3	31.5	48.5
HSL	45 N/mm ²	–	13.2	20.0	29.1	49.7	75.0
Anchor	25 N/mm ²	–	5.7	10.1	12.5	23.7	39.9
HVA	45 N/mm ²	–	8.9	15.0	20.0	36.0	57.9
Anchor	25 N/mm ²	4.2	5.6	7.2	12.8	18.8	24.2
HSA	45 N/mm ²	5.3	9.3	10.5	18.8	22.5	34.1
Anchor	25 N/mm ²	4.4	5.7	8.3	13.4	21.2	25.4
HKD	45 N/mm ²	5.1	7.2	8.7	16.2	28.5	38.0
Anchor	25 N/mm ²	3.2	3.9	6.2	8.7	11.4	15.9
TDD	45 N/mm ²	4.5	6.2	8.6	11.9	14.0	21.0

Concrete strength 25 = concrete $\beta_w \geq 25$ N/mm²

Concrete strength 45 = concrete $\beta_w \geq 45$ N/mm²

Warranty

Hilti provides a warranty for 6 months from the date of invoice with respect to material and manufacturing defects on the DPG 100 test gauge, providing these defects occur despite proper operation and application in accordance with the operating instructions and providing no repairs have been carried out on the gauge. A prerequisite for the provision of the warranty is that the gauge is used exclusively for the inspection and testing of anchors. All other claims, particularly liability claims relating to damage or injury arising from the use of the

gauge, are excluded. A warranty claim is to be made within the framework of our supply conditions immediately upon discovery of the defect. In all respects our general sales conditions apply.

Note:

Malfunctions which occur on account of natural wear and tear, repairs carried out by the owner or third parties, or because of incorrect operation are not covered by this warranty. To ensure measuring accuracy the gauge should be recalibrated every two years.